

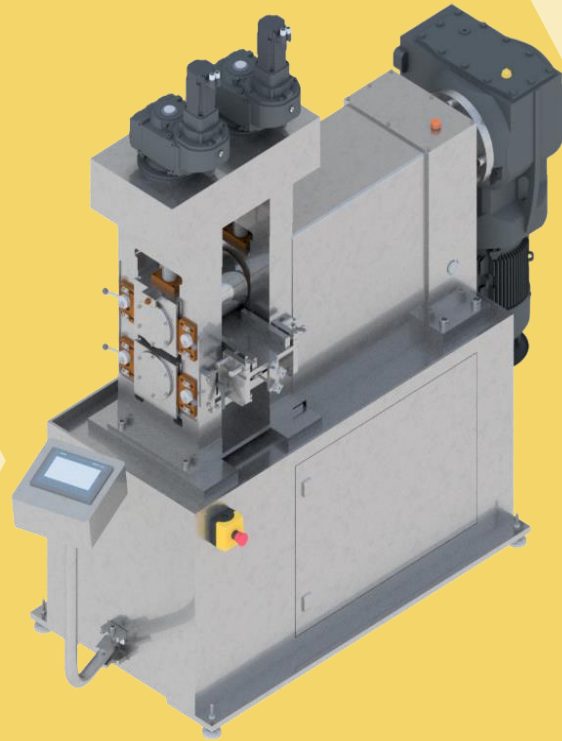

Rolling
and Automation GmbH

RM-S-I-300
RM-S-I-500
RM-S-I-700



INDUSTRIAL SHEET ROLLING MILL



For multiple application fields

- State and Private Mints
- Jewellery Industry
- Semi-finished products
- Research Institutes
- And many more



Choose your options

- Three different main machine sizes
- 2Hi and/or 4Hi
- Two different main drive types
- With or without inner roll cooling
- 3 Types of screw downs
- Leading table with or without side guides



Your benefits

- Various configurations
- Approved quality made in Germany
- Short lead time
- Spare parts always on stock
- Fast ROI

RM ROLLING AND AUTOMATION GMBH

Bergstraße 6, 76307 Karlsbad
+49 160 98284682 | info@rmrolling.de | www.rmrolling.de



Rolling
and Automation GmbH



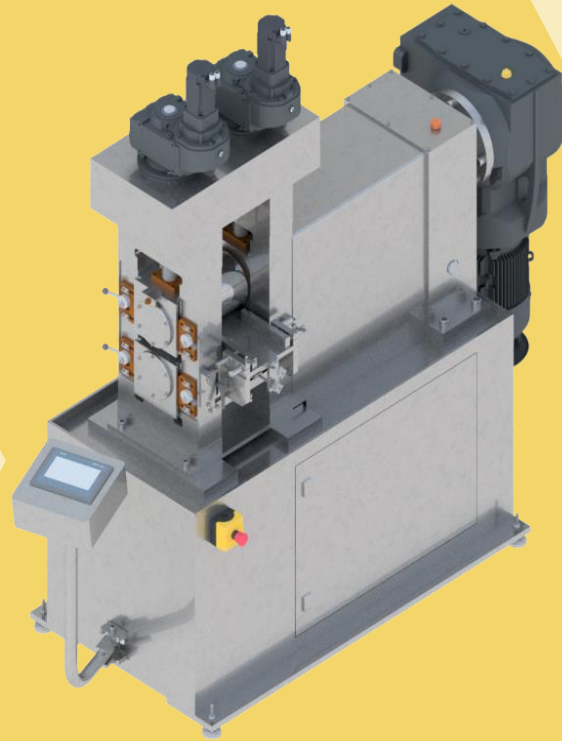

RM-S-I-300
RM-S-I-500
RM-S-I-700



INDUSTRIAL SHEET ROLLING MILL

TYPE	RM-S-I 300		RM-S-I-500		RM-S-I-700		
ROLL SET 2Hi - 4Hi	Ø130 x 150	Ø100/40 x150	Ø180 x 200	Ø120/60 x 200	Ø230 x 200	Ø160/80 x 200	[mm]
BEARING TYPE	CuZn with solid graphite Lubrication						
ROLL FORCE	300	100	500	200	700	400	[kN]
SPEED T_{con}/P_{con}	0-10/15						[m/min]
ROLLING TORQUE - 2 VERSIONS	1800	2700	3.850	5.600	6.100	8.400	[Nm]
POWER MAIN DRIVES	5,50	7,50	7,50	11,00	11,00	15,00	[kW]

CONFIGURATION:

-  **Roll Sets:** 2 Hi and/ or 4 Hi, with or without inner roll cooling
-  **Chiller:** To be connect to your water system or closed loop circulaition with chiller
-  **Main Drive:** Small Torque or High Torque
-  **Screw Down:** Manual with Hand Wheel, Central Servomotoric, Twin Servomotoric
-  **Inserting Table:** Plate or Plate with infinite adjustable side guides

RM ROLLING AND AUTOMATION GMBH

Bergstraße 6, 76307 Karlsbad
+49 160 98284682 | info@rmrolling.de | www.rmrolling.de